

ISO 9001:2015
ISO 14001:2015



CHIEN YOU

PROFILE



CHIEN YOU VIET NAM

TABLE CONTENT

01. ABOUT CHIEN YOU VIET NAM

About us - Mission – Vision - Value **02**

Overview **03**

Organization chart - ISO certificate ISO **04**

02. HOT-DIP GALVANIZING SERVICE

About our plant **06**

Production line **07**

Galvanizing process **08**

Thickness standards **09-10**

Outstanding projects **11-12**

Product images **13**

Statement of performance - Factory of certificate

Product user manual **14**

Certificate **15**

Trusted partners **16**

03. SEMI TRAILER

About our plant **18**

Services **19**

Our products **21-24**

Trusted partners **25**

ABOUT US

Dear Valued Customers/Partners,

Company would like to extend our sincere gratitude and respectful greetings to our valued customers and partners.

Chien You Vietnam Joint Stock Company was established on June 25, 1996, as a member unit of Chien You Industry Corporation (Taiwan). After 29 years of development, we have built a solid trust with our customers and partners, affirming our position in the market. Our main products are various types of semi-trailers for the transportation industry. Additionally, we have expanded into hot-dip galvanizing and metal coating services to meet customer demand for enhanced durability of metal products.

We take pride in being a leading company in the field of semi-trailers and hot-dip galvanizing services in Vietnam, committed to providing the most advanced and quality solutions for our customers. With a professional and experienced team, we continuously strive for innovation and improvement to fully meet market demands. Our operational motto is DEDICATION – INTEGRITY – CREDIBILITY – RESPONSIBILITY, with the goal of building sustainable and long-term relationships with our valued customers and partners.

"We build great things to help our clients achieve great accomplishments".

Thank you very much.

CHAIRMAN



Dao Thanh Bac

MISSION

Create high quality, valuable products that bring customer satisfaction and for a prosperous Vietnam.

VISION

By 2030, become the leading enterprise in Vietnam in the field of Semi-trailers and providing Hot-dip galvanizing services, achieving a revenue of 1,000 billion/year.

VALUE

SINCERITY: Always put all your heart into your work, do everything with care and responsibility. **HONESTY:** Be transparent, straightforward, do not hide information, create trust in customers and colleagues. **REPUTATION:** Keep commitments, ensure quality and progress, build sustainable trust. **RESPONSIBILITY:** Have a high sense of role, be ready to take responsibility and solve problems to the end.

OVERVIEW

1996

Chien You VN was established 1996. Formerly a member unit of Chien You Industry Corporation (Taiwan).

2022

With consensus and trust, the Company established a new Executive Board, ready to lead and develop the organization in a more sustainable and effective direction.

2025

Chien You VN continues to expand capacity, apply advanced technology, affirm its leading position in the field of Semi-trailers and Hot-dip galvanizing, meeting the increasing demands of the domestic and international markets.

2009

Converted from Chien You Viet Nam Company Limited to Chien You Viet Nam Joint Stock Company.

2023

Promote the development of key Semi-Trailer services.
Officially put Hot Dip Galvanizing Technology service into operation.

ORGANIZATION CHART

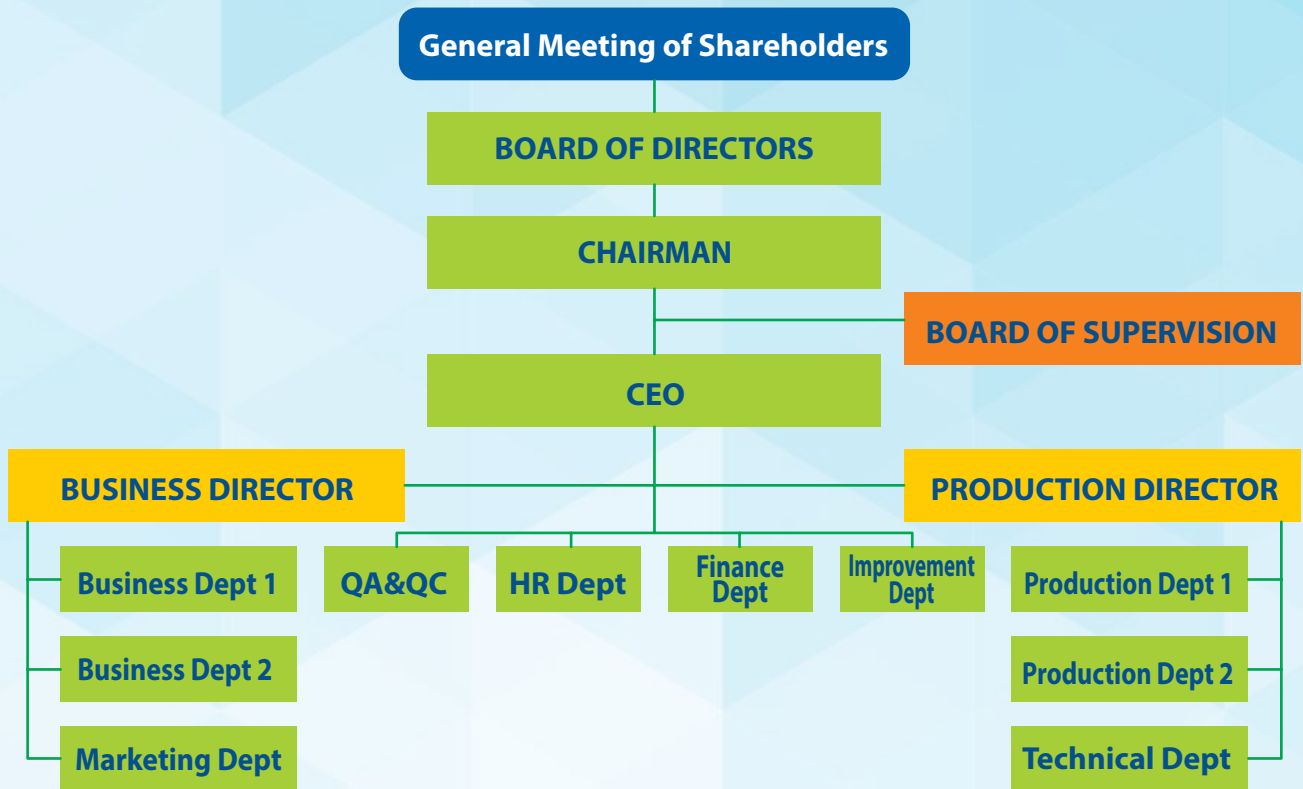

ISO CERTIFICATE





**HOT DIP
GALVANIZING
SERVICES**



ABOUT OUR PLANT



Galvanizing tank W.PILLING - GERMANY

Size:
(Length x Width x Depth)
12,7m x 1,6m x 2,6m

Capacity **4000 tons/month.**

- Treatment tank: Using composite and ceramic technology to coat inner layer of the tank and using the most advanced chemical compounds to best clean iron and steel.
- There are 10 forklifts from 2 to 6 tons.
- There are 9 main cranes over 6 tons.



- The gas system is CNG.
- The air dust removal system is the most advanced system with high efficiency treatment which makes the working environment cleaner.



- 2 auxiliary cranes with capacities of 5 tons and 7 tons
- 2 mobile gantry cranes with capacities of 5 tons and 7 tons
- The plant scale: the number of employees is over 150 people with the area of 3 hectares.

PRODUCTION LINE

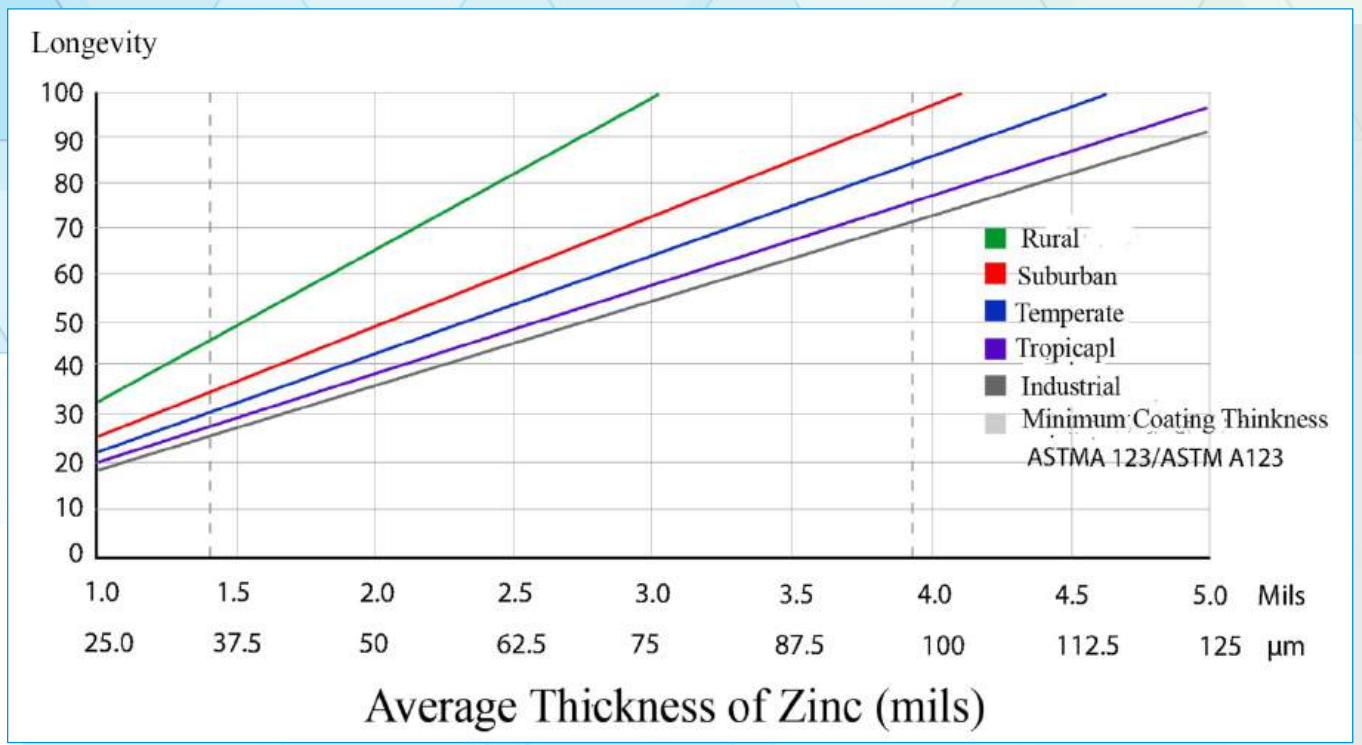
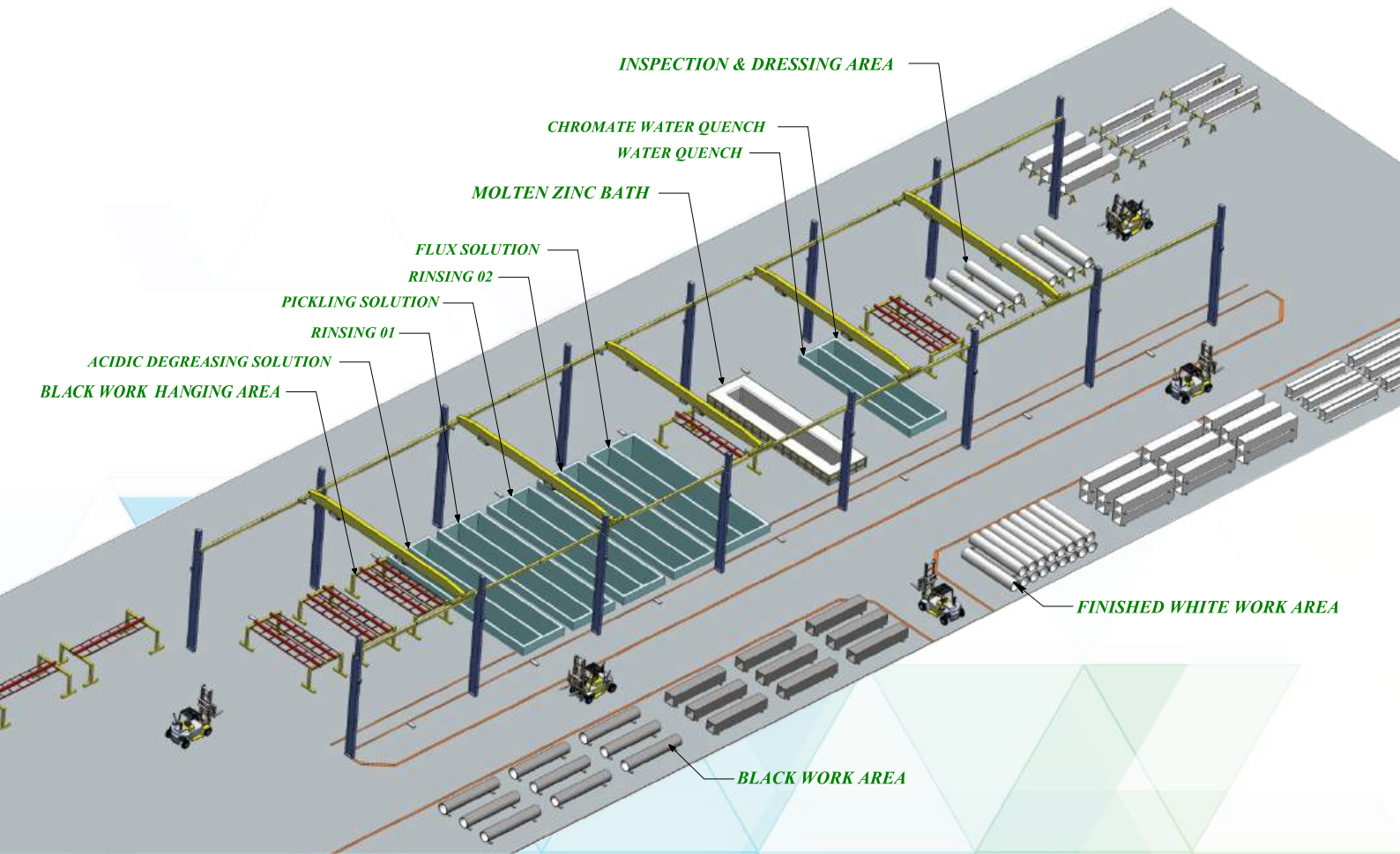

GALVANIZING PROCESS

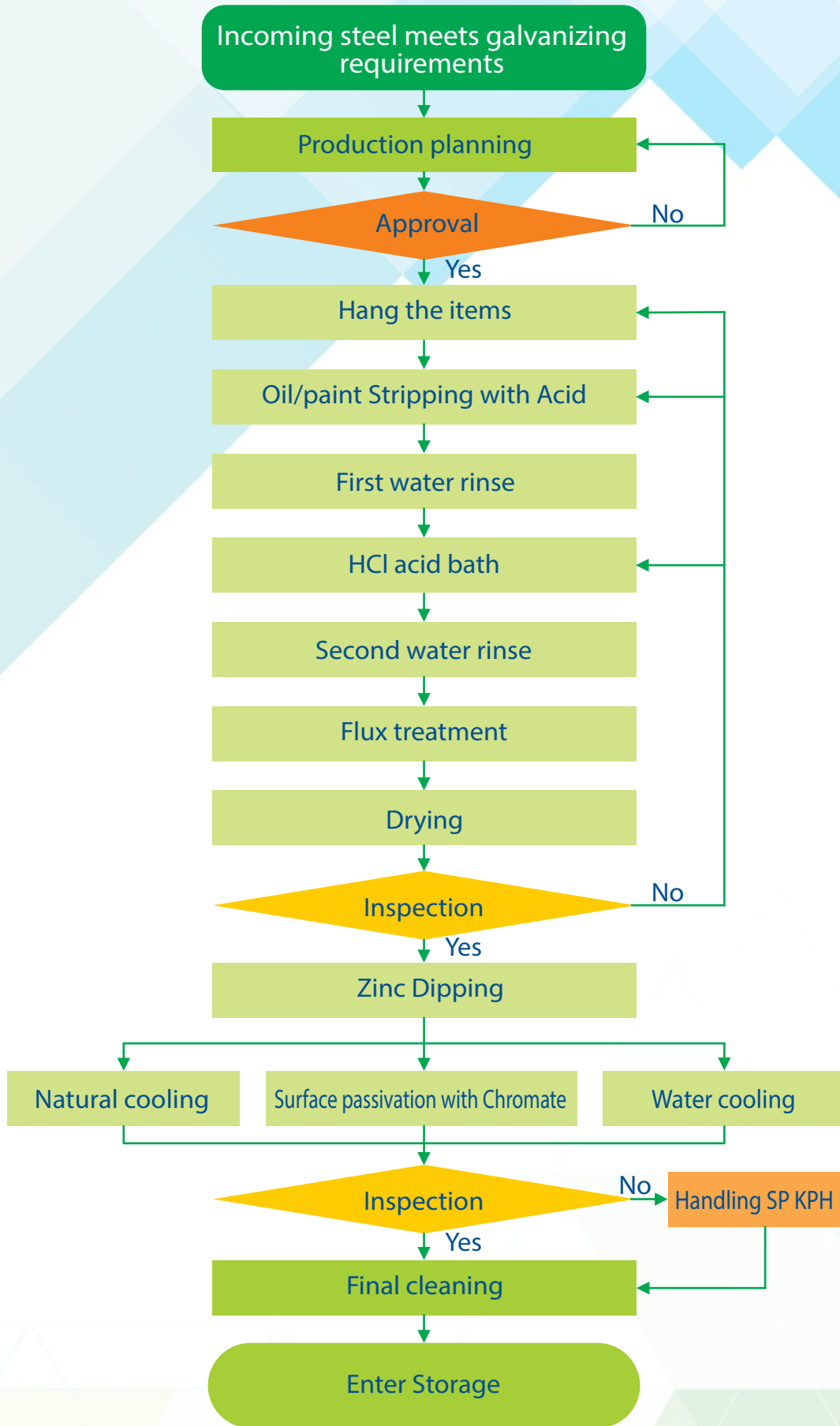

THICKNESS STANDARDS

ASTM A123/A123M-17

MINIMUM AVERAGE COATING THICKNESS GRADE (μm)						
Material Category	All specimens tested					
	< 1.6	≥ 1.6 to < 3.2	≥ 3.2 to 4.8	≥ 4.8 to < 6.4	≥ 6.4 to < 16.0	≥ 16.0
Structural shapes	45	65	75	75	100	100
Strip and Bar	45	65	75	75	75	100
Plate	45	65	75	75	75	100
Pipe and tubing	45	45	75	75	75	75
Wire	35	20	60	65	80	80
Reinforcing bar	100	100

ASTM A153/A153M-16a

THICKNESS OR WEIGHT [MASS] OF ZINC COATING FOR VARIOUS CLASSES OF MATERIAL				
Class of Material	Weight [Mass] of zinc coating, oz/ft ² [g/m ²] of surface, Minimum		Coating thickness, mils [microns], Minimum	
	Average of specimens tested	Any individual specimen	Average of specimens tested	Any individual specimen
Class A-Castings-Malleable Iron, Steel	200 [610]	1.80 [550]	3.4 [86]	3.1 [79]
Class B-Rolled, pressed, and forged articles (except those which would be included under Classes C and D) B-1-5/8 in. [15.88] and over in thickness and over 15 in. [381 mm] in length	200 [610]	1.80 [550]	3.4 [86]	3.1 [79]
B-2-under 5/8 in. [15.88 mm] in thickness and over 15 in. [381 mm] in length	1.50 [458]	1.25 [381]	2.6 [66]	2.1 [53]
B3-any thickness and 15 in. [381 mm] and under in length	1.30 [397]	1.10 [336]	2.5 [56]	1.9 [48]
Class C-Fasteners over 3/8 in. [9.52 mm] in diameter and similar articles. Washers 3/16 in and greater [4.76 mm and greater] in thickness	1.25 [381]	1.00 [305]	2.1 [53]	1.7 [43]
Class D-Fasteners 3/8 in. [9.52 mm] and under in diameter, rivets, nail and similar articles. Washers under 3/16 in. [4.76 mm] in thickness	1.00 [305]	0.85 [259]	1.7 [43]	1.4 [36]

TCVN 5408:2007

MINIMUM COATING THICKNESS ON SAMPLE WITHOUT CENTRIFUGATION		
Article and its thickness	Local coating thickness (minimum) ^a μm	Average coating thickness (minimum) ^b μm
Steel ≥ 6 mm	70	85
Steel ≥ 3 mm to < 6 mm	55	70
Steel $\geq 1,5$ mm to < 3 mm	45	55
Steel < 1,5 mm	35	45
Castings ≥ 6 mm	70	80
Castings < 6 mm	60	70

JIS H8641:2021

Symbols of classification	Example of application ^{a)} (informative)	Minimum coating thickness μm
HDZT 35	Substrate of 5mm or less in thickness, bolts and nuts of 12mm and over in diameter, washers of over 2.3mm in thickness, etc. for which lumpiness and run of zinc is removed by centrifugation or thin coating thickness is required for functional purposes	35
HDZT 42	Substrate of 5mm or less in thickness for which lumpiness and run of zinc is removed by centrifugation or thin coating thickness is required for functional purposes	42
HDZT 49	Substrate of 1mm or over in thickness, bolts and nuts of 12mm and over in diameter, washers of over 2.3mm in thickness	49
HDZT 56	Substrate of 2mm or over in thickness	56
HDZT 63	Substrate of 3mm or over in thickness	63
HDZT 70	Substrate of 5mm or over in thickness	70
HDZT 77	Substrate of 6mm or over in thickness	77

AS/NZS 4680:2006

REQUIREMENTS FOR COATING THICKNESS AND MASS FOR ARTICLES THAT ARE NOT CENTRIFUGED

Article thickness	Local coating thickness (minimum) μm	Average coating thickness (minimum) μm	Average coating mass (minimum) g/m^2
≤ 1.5	35	45	320
$>1.5 \leq 3$	45	55	390
$>3 \leq 6$	55	70	500
> 6	70	85	600

ISO 1461-2009

MINIMUM COATING THICKNESS AND MASS ON SAMPLES THAT ARE NOT CENTRIFUGED

Article and its thickness	Local coating thickness (minimum) ^a μm	Local coating mass (minimum) ^b g/m^2	Mean coating thickness (minimum) ^c μm	Mean coating mass (minimum) ^b g/m^2
Steel > 6 mm	70	505	85	610
Steel > 3 mm to ≤ 6 mm	55	395	70	505
Steel $\geq 1,5$ mm to ≤ 3 mm	45	325	55	395
Steel $< 1,5$ mm	35	250	45	325
Castings ≥ 6 mm	70	505	80	575
Castings < 6 mm	60	430	70	505

OUTSTANDING PROJECTS

ATAD STEEL STRUCTURE

ATAD provides comprehensive solutions for pre-engineered steel buildings and steel structures for a wide range of projects. Chien You Viet Nam is proud to partner with ATAD, supplying over 460 tons of I-beam steel for various projects, including the prominent LAMINEX project exported to Australia.



DAI DUNG CORPORATION

Dai Dung Group is a leading general contractor and steel structure supplier, serving national and international projects. Its products focus on 9 categories, including renewable energy, architecture, high-rise buildings, heavy industry, transportation, transmission steel structures, mechanical engineering, factories, and commercial steel processing. Dai Dung has contributed to over 2,500 projects and exported to 50 countries. Chien You VN has partnered with Dai Dung Group, supplying over 2,300 tons of hot-dip galvanized products for major projects such as Samsung, Novelist, the Lego project in Australia, and Coca-Cola.



HOANG PHUC CONSTRUCTION CONSULTING SERVICES CO., LTD.

With a project of more than 70 tons of railing system protecting both sides of the river at Ninh Kieu wharf - Can Tho.



MAVINEX JOINT STOCK COMPANY **MAVINEX**

Mavinex Joint Stock Company operates in basic construction, supplying equipment for feed mills and livestock farms, with expertise in manufacturing and installing feed silos and automatic feeding systems. Chien You VN is proud to be a hot-dip galvanizing partner, having processed over 1,000 tons of products for Mavinex's livestock farm projects.



VILLAFENCES

Villafences has trusted us to hot-dip galvanize more than 100 tons of fences, railings, door pipes, etc.



JFE MECHANICAL VIETNAM CO.,LTD

JFE MECHANICAL VIETNAM CO., LTD has chosen Chien You VN's Hot Dip Galvanizing service to export products to Japan and use for a large project in Akita Province - Japan.



SED OVERSEA

Partner Sed Oversea with an order of more than 300 tons of hot dip galvanized at Chien You VN.



PRODUCT IMAGES



STATEMENT OF PERFORMANCE - FACTORY OF CERTIFICATE PRODUCT USER MANUAL

CHIEN YOU
ISO 9001:2015
ISO 14001:2015

CÔNG TY CỔ PHẦN CHIENYOU VIỆT NAM
CHIENYOU VIET NAM JOINT STOCK COMPANY

Địa chỉ : Số 12- Đường 3A- Khu Công Nghiệp Biên Hòa 2- Phường An Bình- TP Biên Hòa- Tỉnh Đồng Nai.
Address : No 12- 3A Road- Bien Hoa Industrial Zone 2-An Binh Ward- Bien Hoa City- Dong Nai Province
Điện thoại / Tel: 02513.833.019 Fax: 02513.832.912

GIẤY BẢO HÀNH MẠ KẼM
STATEMENT OF PERFORMANCE FOR HOT DIP GALVANIZING

Ngày / Date: 24/06/2023

Giấy bảo hành này cấp cho / This Statement is issued to

Công ty / Company :
Địa chỉ / Address :
Tên công trình / Project :
Hạng mục / Item :

ĐẶC ĐIỂM / SPECIFICATIONS:

Mô tả kết cấu Description of structure	Đơn vị Unit	Số lượng Quantity	Độ dày Average thick
1			
2			

CHẤT LƯỢNG BẢO HÀNH / ZINC COATING PERFORMANCE:

- Thiết bị đo độ dày lớp mạ / Galvanizing thickness gauge: ELCOMETER-456.
- Đơn vị đo độ dày được quy ra / Thickness unit is converted to: 1 μm = 7.067g/m²
- Bảo hành / Warranty:
- Giấy bảo hành này chỉ có giá trị đối với bản chính/ Only the original of this statement is valid.
- Mạ kẽm được tuân thủ theo tiêu chuẩn/ Galvanization is compliance with: ASTM A123/A123M-17
- Bảo hành lớp mạ kẽm ở môi trường bình thường là 10 năm. Không bảo hành lớp mạ kẽm ở môi trường nước biển, nước lợ, nước axit và môi trường ngập nước. Warranty of the zinc coating in normal environment is 10 years. Not warranty is applied in conditions: seawater, brackish water, acid water and submerged environment .

QUẢN LÝ CHẤT LƯỢNG **CTY CP CHIEN YOU VIỆT NAM**

CHIEN YOU
ISO 9001:2015
ISO 14001:2015

CÔNG TY CỔ PHẦN CHIENYOU VIỆT NAM
CHIENYOU VIET NAM JOINT STOCK COMPANY

Địa chỉ : Số 12- Đường 3A- Khu Công Nghiệp Biên Hòa 2- Phường An Bình- TP Biên Hòa- Tỉnh Đồng Nai.
Address : No 12- 3A Road- Bien Hoa Industrial Zone 2-An Binh Ward- Bien Hoa City- Dong Nai Province
Điện thoại / Tel: 02513.833.019 Fax: 02513.832.912

GIẤY CHỨNG NHẬN XUẤT XỨNG
FACTORY OF CERTIFICATE

Ngày / Date: 24/06/2023

Giấy chứng nhận xuất xứ này cấp cho / This Statement is issued to

Công ty / Company :
Địa chỉ / Address :
Tên công trình / Project :
Hạng mục / Item :

ĐẶC ĐIỂM / SPECIFICATIONS:

CHẤT LƯỢNG BẢO HÀNH / ZINC COATING PERFORMANCE:

- Sản phẩm được nhúng kẽm phù hợp với tiêu chuẩn: ASTM-A123/A123M- 17/ The Product is made in accordance with ASTM-A123/A123M- 17 standard
- Độ phủ theo tiêu chuẩn : Đạt --- Coverage according to standard : Pass
- Độ bám dính theo tiêu chuẩn : Đạt --- Adhesion according to standard : Pass
- Standard brightness : Pass
- ating thickness gauge: ELCOMETER-456. product is guaranteed to be out in to use .

CTY CP CHIEN YOU VIỆT NAM

CHIEN YOU

CÔNG TY CỔ PHẦN CHIENYOU VIỆT NAM
CHIENYOU VIET NAM JOINT STOCK COMPANY

Địa chỉ : Số 12- Đường 3A- Khu Công Nghiệp Biên Hòa 2- Phường An Bình- TP Biên Hòa- Tỉnh Đồng Nai.
Address : No 12- 3A Road- Bien Hoa Industrial Zone 2-An Binh Ward- Bien Hoa City- Dong Nai Province
Điện thoại / Tel: 02513.833.019 Fax: 02513.832.912

MAINTENANCE AND CLEANING GUIDELINES FOR HOT-DIP GALVANIZED PRODUCTS

1. Definition:

- Hot-dip galvanized products are those that are alloyed between zinc and steel or steel structures.
- Zinc is coated on the surface of the product to protect the steel or steel structure.

2. Storage and Usage Instructions:^a

- If the hot-dip galvanized product is not installed immediately, it should be stored in a dry, well-ventilated area, avoiding long-term storage in humid and poorly ventilated conditions.
- Hot-dip galvanized products should not be used, and usage should be limited in the following environments:
 - Environments with strong acidity (pH \leq 6) or strong alkalinity (pH \geq 12).
 - Environments exposed to seawater or sea mist.
 - Environments that are excessively hot and humid, lacking ventilation, leading to moisture accumulation.
 - Avoid direct contact between galvanized steel products and other metals, such as brass and copper, especially in corrosive environments. When different metals are used together, ensure there is an insulating material between the other metals and the galvanized product.

3. Surface Maintenance:^a

- Use plastic or cloth cleaning tools to clean the surface of the galvanized coating.
- Do not use metal cleaning tools to clean the surface of the galvanized coating, as this will scratch, wear down, or damage the galvanized coating.
- Use clean freshwater or a cleaning agent with a pH between 6 and 12 to regularly clean the surface of the galvanized coating, especially when used in highly corrosive environments.

* References: 1) "ADVISORY NOTE 31- CARE AND MAINTENANCE OF HOT DIP GALVANIZED COATINGS" Issue 3: September 2021 - Galvanizers Association of Australia
2) "MAINTENANCE AND CLEANING GALVANIZED STEEL" - Galvanizers Association of Australia

QA/QC Manager: HA THANH TAM
Technical Manager: BUI DINH DOC
Board of Directors: ĐÀO THANH BẠC

CERTIFICATE

ISOCERT
International Certification and Inspection

CERTIFICATE
No. 9199293413290-06-PRO

PRODUCT CERTIFICATE:
NOT FOR ADVERTISING PURPOSES ON METAL PRODUCTS.

PRODUCED AT:
CHIEN YOU VIET NAM JOINT STOCK COMPANY
Head Office and Factory No. 13, 15 Street, Hoa Hai Industrial Park,
Ho Chi Minh, Binh Duong City, Hoang Phung, Vietnam.

This has been assessed and found to conform with requirements of the following standard:
ASTM A123/A123M-17
Mode of verification: Method 5 - Circular 26201/2017/18/HCN date 13/12/2012
and Circular 02/2017/TT-BKHCHN date 31/09/2017.

Certification date: 18 May 2023
Issue date: 2nd issue - 08 Jun 2024
Expiration date: 18 May 2026
Details in decision No.: 0992410500-ISOCERT

Check the validity of the certificate information with our website at
ISOCERT INTERNATIONAL CERTIFICATION AND INSPECTION JOINT STOCK COMPANY
No. 41 A Street, Binh Duong City, Ho Chi Minh, Binh Duong, Hoang Phung, Vietnam.
Head Office: 13/15 Street, Hoa Hai Industrial Park, Binh Duong City, Hoang Phung, Vietnam. Website: www.isocert.com

ISOCERT
International Certification and Inspection

CERTIFICATE
No. 9199293413290-03-PRO

PRODUCT CERTIFICATE:
NOT FOR ADVERTISING PURPOSES ON METAL PRODUCTS.

PRODUCED AT:
CHIEN YOU VIET NAM JOINT STOCK COMPANY
Head Office and Factory No. 13, 15 Street, Hoa Hai Industrial Park,
Ho Chi Minh, Binh Duong City, Hoang Phung, Vietnam.

This has been assessed and found to conform with requirements of the following standard:
BS EN ISO 1461:2009
Mode of verification: Method 5 - Circular 26201/2017/18/HCN date 13/12/2012
and Circular 02/2017/TT-BKHCHN date 31/09/2017.

Certification date: 18 May 2023
Issue date: 2nd issue - 08 Jun 2024
Expiration date: 18 May 2026
Details in decision No.: 1992410500-ISOCERT

Check the validity of the certificate information with our website at
ISOCERT INTERNATIONAL CERTIFICATION AND INSPECTION JOINT STOCK COMPANY
No. 41 A Street, Binh Duong City, Ho Chi Minh, Binh Duong, Hoang Phung, Vietnam.
Head Office: 13/15 Street, Hoa Hai Industrial Park, Binh Duong City, Hoang Phung, Vietnam. Website: www.isocert.com

ISOCERT
International Certification and Inspection

CERTIFICATE
No. 9199293413290-05-PRO

PRODUCT CERTIFICATE:
NOT FOR ADVERTISING PURPOSES ON METAL PRODUCTS.

PRODUCED AT:
CHIEN YOU VIET NAM JOINT STOCK COMPANY
Head Office and Factory No. 13, 15 Street, Hoa Hai Industrial Park,
Ho Chi Minh, Binh Duong City, Hoang Phung, Vietnam.

This has been assessed and found to conform with requirements of the following standard:
ASTM A153/A153M-16a
Mode of verification: Method 5 - Circular 26201/2017/18/HCN date 13/12/2012
and Circular 02/2017/TT-BKHCHN date 31/09/2017.

Certification date: 18 May 2023
Issue date: 2nd issue - 08 Jun 2024
Expiration date: 18 May 2026
Details in decision No.: 0992410500-ISOCERT

Check the validity of the certificate information with our website at
ISOCERT INTERNATIONAL CERTIFICATION AND INSPECTION JOINT STOCK COMPANY
No. 41 A Street, Binh Duong City, Ho Chi Minh, Binh Duong, Hoang Phung, Vietnam.
Head Office: 13/15 Street, Hoa Hai Industrial Park, Binh Duong City, Hoang Phung, Vietnam. Website: www.isocert.com

ISOCERT
International Certification and Inspection

CERTIFICATE
No. 9199293413290-01-PRO

PRODUCT CERTIFICATE:
NOT FOR ADVERTISING PURPOSES ON METAL PRODUCTS.

PRODUCED AT:
CHIEN YOU VIET NAM JOINT STOCK COMPANY
Head Office and Factory No. 13, 15 Street, Hoa Hai Industrial Park,
Ho Chi Minh, Binh Duong City, Hoang Phung, Vietnam.

This has been assessed and found to conform with requirements of the following standard:
TCVN 5408:2007 (ISO 1461:1999)
Mode of verification: Method 5 - Circular 26201/2017/18/HCN date 13/12/2012
and Circular 02/2017/TT-BKHCHN date 31/09/2017.

Certification date: 18 May 2023
Issue date: 2nd issue - 08 Jun 2024
Expiration date: 18 May 2026
Details in decision No.: 0992410500-ISOCERT

Check the validity of the certificate information with our website at
ISOCERT INTERNATIONAL CERTIFICATION AND INSPECTION JOINT STOCK COMPANY
No. 41 A Street, Binh Duong City, Ho Chi Minh, Binh Duong, Hoang Phung, Vietnam.
Head Office: 13/15 Street, Hoa Hai Industrial Park, Binh Duong City, Hoang Phung, Vietnam. Website: www.isocert.com

ISOCERT
International Certification and Inspection

CERTIFICATE
No. 9199293413290-02-PRO

PRODUCT CERTIFICATE:
NOT FOR ADVERTISING PURPOSES ON METAL PRODUCTS.

PRODUCED AT:
CHIEN YOU VIET NAM JOINT STOCK COMPANY
Head Office and Factory No. 13, 15 Street, Hoa Hai Industrial Park,
Ho Chi Minh, Binh Duong City, Hoang Phung, Vietnam.

This has been assessed and found to conform with requirements of the following standard:
JIS H8641:2021
Mode of verification: Method 5 - Circular 26201/2017/18/HCN date 13/12/2012
and Circular 02/2017/TT-BKHCHN date 31/09/2017.

Certification date: 18 May 2023
Issue date: 2nd issue - 08 Jun 2024
Expiration date: 18 May 2026
Details in decision No.: 0992410500-ISOCERT

Check the validity of the certificate information with our website at
ISOCERT INTERNATIONAL CERTIFICATION AND INSPECTION JOINT STOCK COMPANY
No. 41 A Street, Binh Duong City, Ho Chi Minh, Binh Duong, Hoang Phung, Vietnam.
Head Office: 13/15 Street, Hoa Hai Industrial Park, Binh Duong City, Hoang Phung, Vietnam. Website: www.isocert.com

ISOCERT
International Certification and Inspection

CERTIFICATE
No. 9199293413290-04-PRO

PRODUCT CERTIFICATE:
NOT FOR ADVERTISING PURPOSES ON METAL PRODUCTS.

PRODUCED AT:
CHIEN YOU VIET NAM JOINT STOCK COMPANY
Head Office and Factory No. 13, 15 Street, Hoa Hai Industrial Park,
Ho Chi Minh, Binh Duong City, Hoang Phung, Vietnam.

This has been assessed and found to conform with requirements of the following standard:
AS/NZS 4680:2006
Mode of verification: Method 5 - Circular 26201/2017/18/HCN date 13/12/2012
and Circular 02/2017/TT-BKHCHN date 31/09/2017.

Certification date: 18 May 2023
Issue date: 2nd issue - 08 Jun 2024
Expiration date: 18 May 2026
Details in decision No.: 1992410500-ISOCERT

Check the validity of the certificate information with our website at
ISOCERT INTERNATIONAL CERTIFICATION AND INSPECTION JOINT STOCK COMPANY
No. 41 A Street, Binh Duong City, Ho Chi Minh, Binh Duong, Hoang Phung, Vietnam.
Head Office: 13/15 Street, Hoa Hai Industrial Park, Binh Duong City, Hoang Phung, Vietnam. Website: www.isocert.com

 **Member**
American Galvanizers Association
Protecting Steel for a Sustainable Future

Certificate of Membership
Chien You Viet Nam Joint Stock
Member 2024



Melissa Lindsley
Melissa Lindsley, Executive Director

TRUSTED PARTNERS





SEMI TRAILER

ABOUT OUR PLANT

Capacity: 100 Trailers/month.



SERVICES



Warranty - Repairs

- All main beams of semi-trailer - Chien You Vietnam are warranted for 3 years.
- Assembled components are warranted for 1 year at Chien You Vietnam Joint Stock Company.
- Businesses can easily maintain vehicles, saving costs.



Warranty terms:

Warranty and repair are free of charge when:

- The product has a valid warranty period
- Product damage due to manufacturer's technical error

Products are not covered by warranty and repairs are available for a fee:

- Components wear out.
- Operating incorrectly according to design and technical requirements. There is external impact, fire and explosion...
- Due to the influence of weather and corrosive chemicals. Natural wear and tear due to use...
- Change structure, replace non-genuine spare parts. Damage caused by improper repair...
- The product is out of warranty period.



Painting service

- The most advanced machinery such as CNC cutting machines and automatic welding ensure a precise and sturdy structure.
- Before painting, the SMRM surface is cleaned with a shot blasting system according to SA 2.5 standards to increase the adhesion of the paint. Then prime, and color coat according to customer requirements.

Transport & Container Lifting



Spare parts & Components

Chien You Vietnam Joint Stock Company provides a variety of semi-trailer spare parts guaranteed to be genuine. When purchasing semi-trailer spare parts at Chien You Vietnam, customers can rest assured with product quality and perfect service.

- Competitive prices with commitment to good quality products.
- Delivery according to contract.
- Use professional shipping services nationwide.
- Get support from consultation, purchase, service use and after-sale.



NIPPON STEEL CORPORATION SAKAI

Made in Japan.
Specs: SM490YA 40LB.
Size: 457 x 152 x 60.
Length: 12m.



Mechanical service

75% of semi-trailers are steel, so CHIEN YOU only chooses specialized high-strength steel for semi-trailer production.

- Casting steel SM 490YA Nippon Steel – Made in Japan. **Thickness up to 40LB.**
- System of tie bars, bearings, locking humps: SCW49 monolithic cast steel.



OUR PRODUCTS

CY3SCE 18

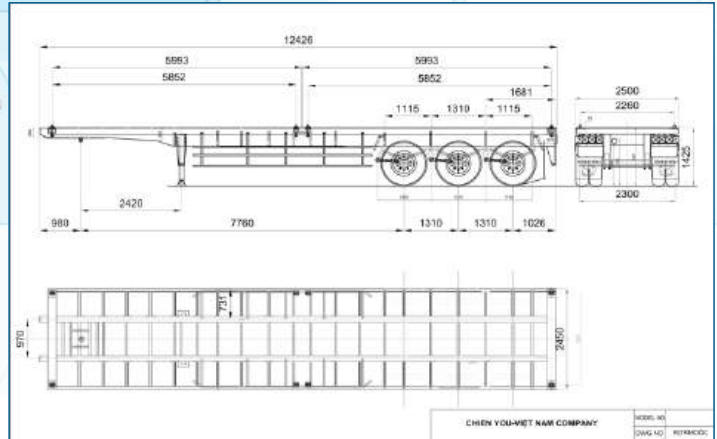

Length x Width x Height	12.425 x 2.500 x 1.455 (mm).
Wheelbase	7.760 + 1.310 + 1.310 (mm).
Payload/Total load	31.550 Kg/38.760 kg.
Main Beam	Casting steel SM 490YA Nippon steel – Made in Japan. Thickness up to 40LB.
Kingpin	JOST 2 inch, weld type.
Stand	FUWA 28/80 tons, 2-speed manual.
Axles	FUWA 13 tons, 10 bolt.
Suspension systems	1.100 x 100 x 12mm x 10 leaf spring.
Torque arm system, Spring seat, Fasten con't	Solid cast steel SCW49.
Double air brake compartment	Seat 1(1 floor), seat 2, 3 (2 floor).
Braking system	Sealco relay valves, USA.
Tires	11.00-20 (18PR).
Wheel	750 x 20 x 10 hole.
Paint	Spraying, primer, color coating as required.

CY3SCE 35

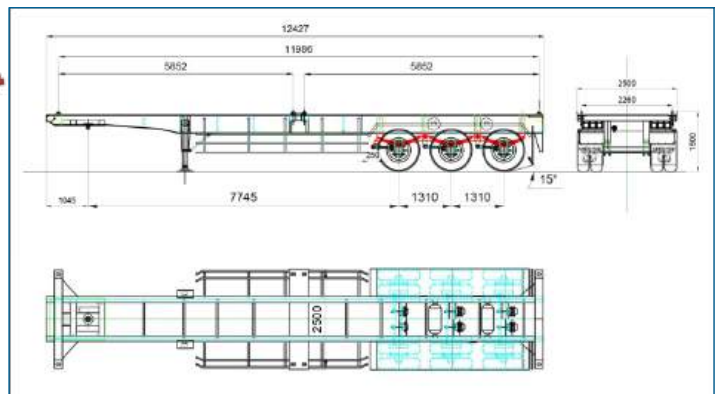

Length x Width x Height	12.425 x 2.500 x 1.500 (mm).
Wheelbase	7.745 + 1.310 + 1.310 (mm).
Payload/Total load	33.235 Kg/39.085 kg.
Main Beam	Casting steel SM 490YA Nippon steel – Made in Japan. Thickness up to 40LB.
Kingpin	JOST 2 inch, bolt type.
Stand	FUWA 28/80 tons, 2-speed manual.
Axles	FUWA 13 tons, 10 bolt.
Suspension systems	1.100 x 100 x 12mm x 10 leaf spring.
Torque arm system, Spring seat, Fasten con't	Solid cast steel SCW49.
Double air brake compartment	seat 1, 2, 3 (2 floor).
Braking system	Sealco relay valves, USA.
Tires	11R22.5 (16PR), 11.00-20 (18PR), 12R225 (18PR).
Wheel	8.25 x 22.5 x 10 hole, 750V x 20 x 10 hole.
Paint	Spraying, primer, color coating as required.

CYSCD 10

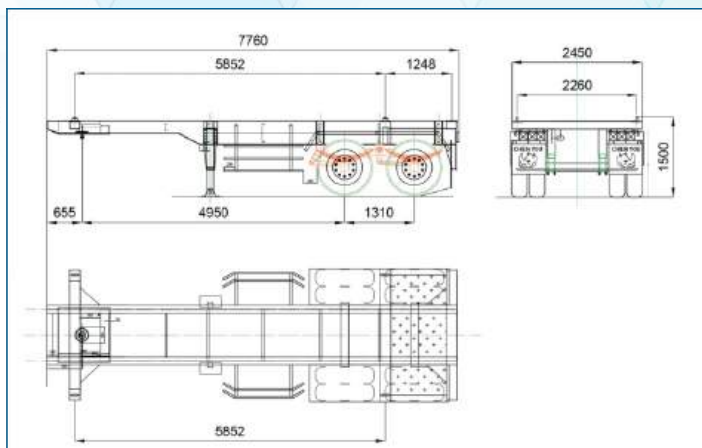

Length x Width x Height	7.760 x 2.450 x 1.500 (mm).
Wheelbase	4.950 + 1.310 (mm).
Payload/Total load	29.850 Kg/33.760 kg.
Main Beam	Casting steel SM 490YA Nippon steel – Made in Japan. Thickness up to 40LB.
Kingpin	JOST 2 inch, bolt type.
Stand	FUWA 28/80 tons, 2-speed manual.
Axles	FUWA 13 tons, 10 bolt.
Suspension systems	1.100 x 100 x 12mm x 10 leaf spring.
Torque arm system, Spring seat, Fasten con't	Solid cast steel SCW49.
Double air brake compartment	seat 1, 2 (2 floor).
Braking system	Sealco relay valves, USA.
Tires	11R22.5 (16PR), 11.00-20 (18PR), 12R225 (18PR).
Wheel	8.25 x 22.5 x 10 hole, 750V x 20 x 10 hole.
Paint	Spraying, primer, color coating as required.

YSC 449

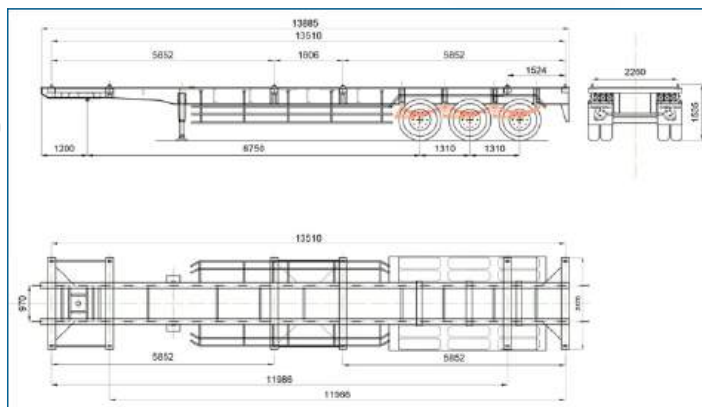

Length x Width x Height	13.885 x 2.470 x 1.535 (mm).
Wheelbase	8.750 + 1.310 + 1.310 (mm).
Payload/Total load	32.470 Kg/38.900 kg.
Main Beam	Casting steel SM 490YA Nippon steel – Made in Japan. Thickness up to 40LB.
Kingpin	JOST 2 inch, weld type.
Stand	FUWA 28/80 tons, 2-speed manual.
Axles	FUWA 13 tons, 10 bolt.
Suspension systems	1.100 x 100 x 12mm x 10 leaf spring.
Torque arm system, Spring seat, Fasten con't	Solid cast steel SCW49.
Double air brake compartment	Seat 1, 2, 3 (2 floor).
Braking system	Sealco relay valves, USA.
Tires	11.00-20 (18PR).
Wheel	750 x 20 x 10 hole.
Paint	Spraying, primer, color coating as required.

YSC 456-3

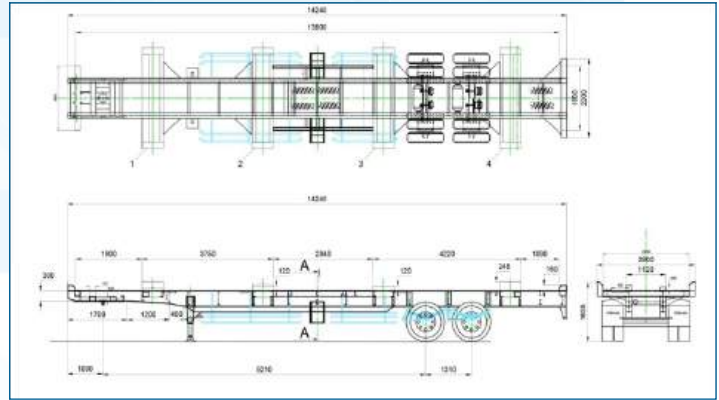

Length x Width x Height	14.120 x 2.800 x 1.655 (mm).
Wheelbase	9.210 + 1.310 (mm).
Payload/Total load	53.000 Kg/60.000 kg.
Main Beam	Casting steel SM 490YA Nippon steel – Made in Japan. Thickness up to 40LB.
Kingpin	JOST 2 inch, weld type.
Stand	FUWA 28/80 tons, 2-speed manual.
Axles	FUWA 13 tons, 10 bolt.
Suspension systems	1.100 x 100 x 12mm x 10 leaf spring.
Torque arm system, Spring seat, Fasten con't	Solid cast steel SCW49.
Double air brake compartment	Seat 1(1 floor), seat 2 (2 floor).
Braking system	Sealco relay valves, USA.
Tires	11.00-20 x 20PR.
Wheel	750 x 20 x 10 hole.
Paint	Spraying, primer, color coating as required.

YSC 456-4

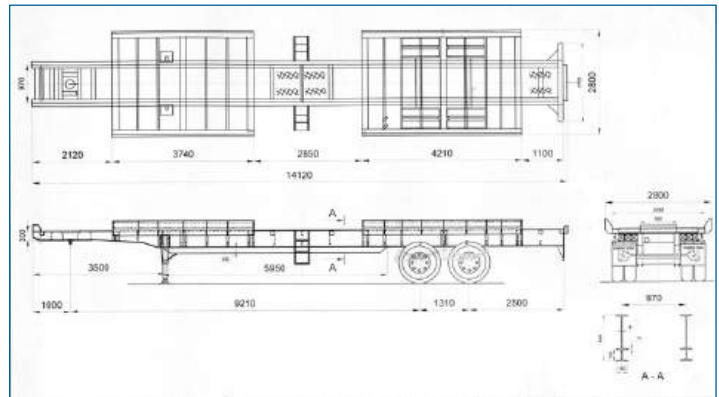

Length x Width x Height	14.120 x 2.800 x 1.655 (mm)
Wheelbase	9.210 + 1.310 (mm)
Payload/Total load	53.000 Kg/60.000 kg.
Main Beam	Casting steel SM 490YA Nippon steel – Made in Japan. Thickness up to 40LB.
Kingpin	JOST 2 inch, weld type.
Stand	FUWA 28/80 tons, 2-speed manual.
Axles	FUWA 13 tons, 10 bolt.
Suspension systems	1.100 x 100 x 12mm x 10 leaf spring.
Torque arm system, Spring seat, Fasten con't	Solid cast steel SCW49.
Double air brake compartment	Seat 1(1 floor), seat 2 (2 floor).
Braking system	Sealco relay valves, USA.
Tires	11.00-20 x 20PR.
Wheel	750 x 20 x 10 hole.
Paint	Spraying, primer, color coating as required.

YSC 679

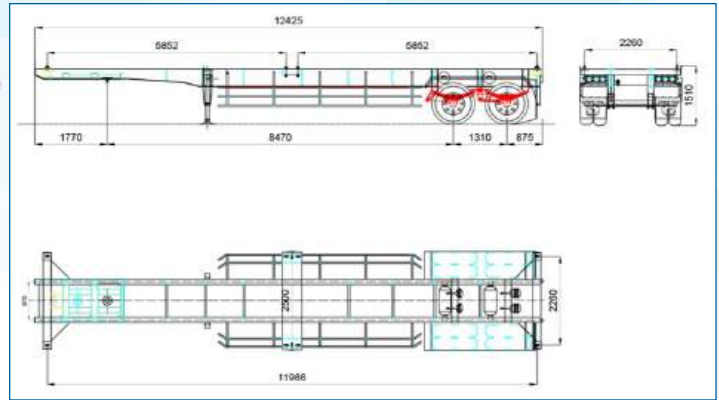

Length x Width x Height	12.425 x 2.500 x 1.510 (mm).
Wheelbase	8.470 + 1.310 (mm).
Payload/Total load	29.420 Kg/34.230 kg.
Main Beam	Casting steel SM 490YA Nippon steel – Made in Japan. Thickness up to 40LB.
Kingpin	JOST 2 inch, bolt type.
Stand	FUWA 28/80 tons, 2-speed manual.
Axles	FUWA 13 tons, 10 bolt.
Suspension systems	1.100 x 100 x 12mm x 10 leaf spring.
Torque arm system, Spring seat, Fasten con't	Solid cast steel SCW49.
Double air brake compartment	seat 1, 2 (2 floor).
Braking system	Sealco relay valves, USA.
Tires	11R22.5 (16PR) , 11.00-20 (18PR), 12R225 (18PR).
Wheel	8.25 x 22.5 x 10 hole, 750V x 20 x 10 hole.
Paint	Spraying, primer, color coating as required.

YSC 632

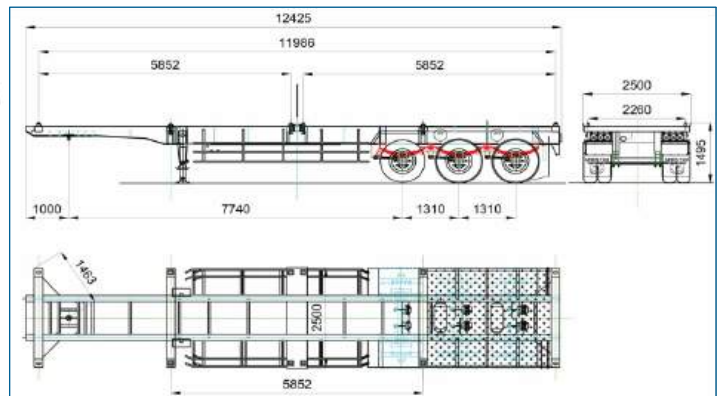

Length x Width x Height	12.425 x 2.500 x 1.495 (mm).
Wheelbase	7.740 + 1.310 + 1.310 (mm).
Payload/Total load	32.640 Kg/38.690 kg.
Main Beam	Casting steel SM 490YA Nippon steel – Made in Japan. Thickness up to 40LB.
Kingpin	JOST 2 inch, bolt type.
Stand	FUWA 28/80 tons, 2-speed manual.
Axles	FUWA 13 tons, 10 bolt.
Suspension systems	1.100 x 100 x 12mm x 10 leaf spring.
Torque arm system, Spring seat, Fasten con't	Solid cast steel SCW49.
Double air brake compartment	Seat 1, 2, 3 (2 floor).
Braking system	Sealco relay valves, USA.
Tires	11R22.5 (16PR) , 11.00-20 (18PR), 12R225 (18PR).
Wheel	8.25 x 22.5 x 10 hole, 750V x 20 x 10 hole.
Paint	Spraying, primer, color coating as required.

TRUSTED PARTNERS





thank you

Chien You Company is very pleased to cooperate and accompany partners and customers in large and small projects. We are committed to bringing the best quality products and services.

For more details, please connect with us with the information below.



CHIEN YOU VIET NAM



Add: No.12, Road 3A, Bien Hoa II Industrial Zone, An Binh Ward, Bien Hoa City, Dong Nai, Viet Nam.

Tell: + (84-0) 913 940 036 | + (84-0) 251 3 833 019 | Email: info@chienyouvn.com

Website: www.chienyouvn.com